

Product specification

Switch mode power supply 19" Twinvolt: MPS10012/05

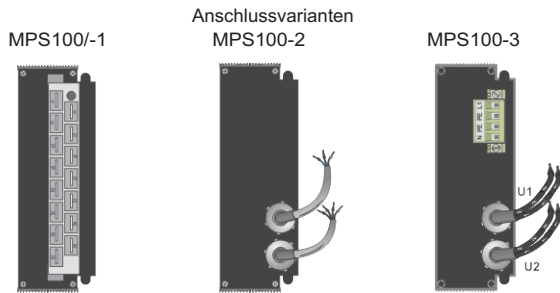
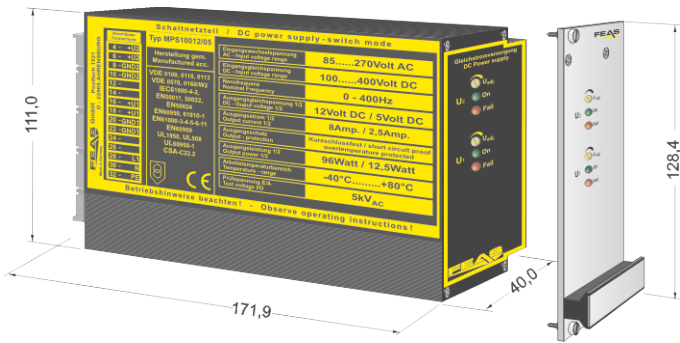

- Input range: 85 - 270 V_{AC} or 100 - 400V_{DC}
- 2 galvanically isolated outputs
- Output range: 10.0 - 15.5 V_{DC} / 3.2 - 6.2 V_{DC}
- also adverse voltage possible
- Power: 96 W / 12.5 W
- Operating status shown by LED
- 19" rack mounting (3HE 8 TE) different terminal dispositions
- Parallel operation possible, short circuit proof, overload and open circuit protected
- Vibration proof, suitable for the tropics - epoxy resin casted
- Output separated according to VDE0570
- Conforms to EMC and low voltage directive
- Safety according to VDE, EN, UL, CSA

Application

The switch-mode power supplies of the MPS100 series are powerful and robust devices to power sensitive loads in a hard industrial environment. These features result from the modern construction with a good radio shielding and high reliability integrated in a functional and stable casing.

The two short circuit proof output DC voltages of this model are independent from each other and can be adjusted.

This power supply is optimally suited for loads requiring high starting currents.

Functional principle

In the power supplies of the series MPS100 a flyback converter operates to transform the energy in two steps.

During the conducting phase the diode is blocking, the inductor is energized and a magnetic field establishes. There is no electrical transmission; the consumer load is supplied with energy from the capacitor.

When the switching transistor opens, the blocking phase begins. The current in the inductor cannot change immediately, discharges through the diode and a negative voltage establishes at the inductor.

Now operating like a power source the inductor reloads the capacitor and supplies the consumer with energy.

The energy flows from the inductor into the capacitor and the consumer and through the conducting diode back to the inductor.

Design

Completely embedded with resin in a metal cassette acc. to DIN 41494 for 19"-rack (3RU 8HP).

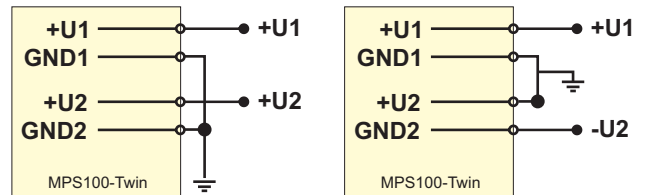

Wiring diagrams to realize adverse voltage.

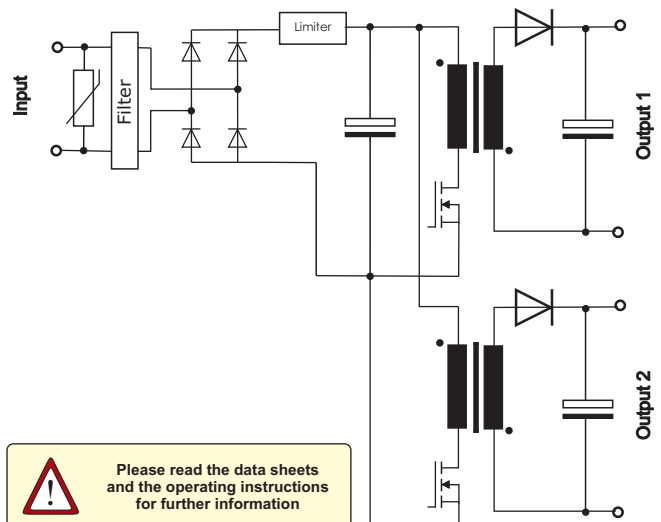
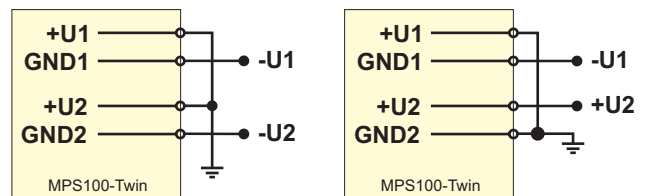

Please read the data sheets and the operating instructions for further information



Postfach 1521
D - 22905 Ahrensburg

Phone: +49 4102 42082
Telefax: +49 4102 40930

E-Mail : sales@feas.com
Internet: www.feas.com