

# product specification

## 3 channel relay coupler - normally open contacts: **RKS1-3**

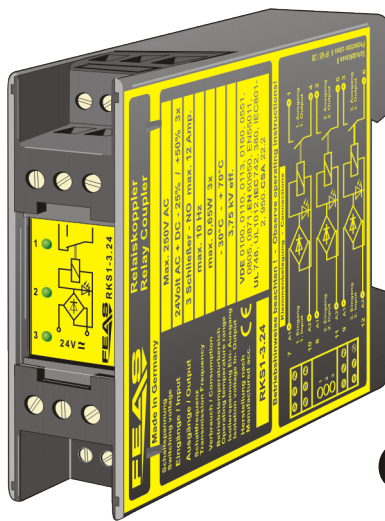

- Outputs potential-free
- Input suited for AC and DC voltage
- Operating status shown by LED
- Noble metal contacts for greater switching performance
- Simple mounting on rail acc. to DIN 46277
- Conforms to EMC and low voltage directive  $\text{CE}$
- Safety acc. to VDE, EN, UL, CSA

### Application

Whenever levels and power have to be matched, as is the case for low switching frequencies, electromechanical relays are the preferred choice as interface components between peripheral process devices and the control logic. In principle, electromechanical relays are divided into two main categories, monostable and bistable. Monostable AC or DC - relays return their switch contacts to a non-operative state independently after coil current has been switched off. Bistable relays, on the other hand, leave their switch contacts in the last switched position after the energising current has been interrupted.

Relays convince with their robust construction and their inexpensive and universal practical suitability. However, their possible application is limited because of relatively low switching frequencies.

Safe operation of the relays can be affected by capacitive or inductive interference voltage which can be inductively coupled into the supply wiring of the relay coil. Supply wiring which has been laid over long distances and in parallel with high currents conductors is frequently the cause of this inductive coupling. If the inductively coupled interference voltage is greater than the break voltage of the relay, it is possible that the relay can no longer be released. It is therefore recommended that this be borne in mind when laying the control wiring. The level of interference voltage can be effectively suppressed by the connection of an RC module parallel to the relay coil.

The ambient temperature at the place of operation has a fundamental influence on some relay operating parameters. In particular, it influences the values for the make and break voltages. These voltages rise with increasing ambient temperature and the additional attendant heating up of the relay coils. At the same time the maximum permitted coil voltage decreases, and as a result limits the scope of application for the relay.

### Functional principle

To enable DC or AC operations with one and the same relay, a bridge rectifier is connected to the input circuit. Two bridge rectifier diodes then take on the dumping function and therefore limit the switch-off voltage arising at the coil to approx. 1.4 volts. In addition, the bridge rectifier also prevents a possible reverse polarity of the control voltage.

### Design

Completely embedded with resin in a plastics housing for mounting on a rail.

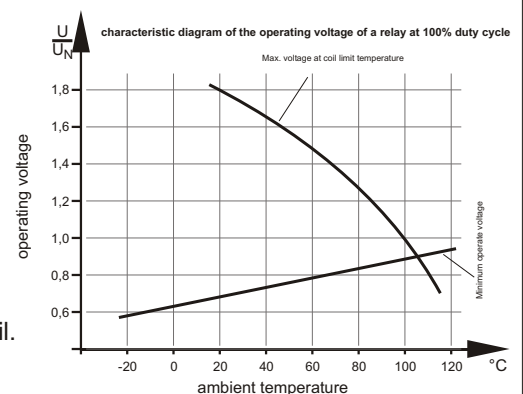
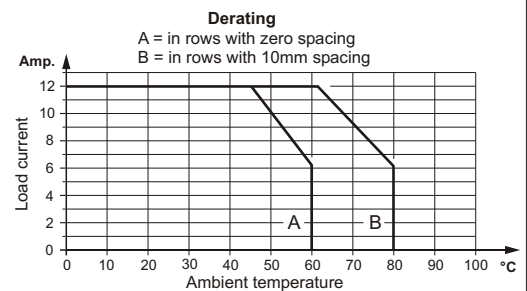
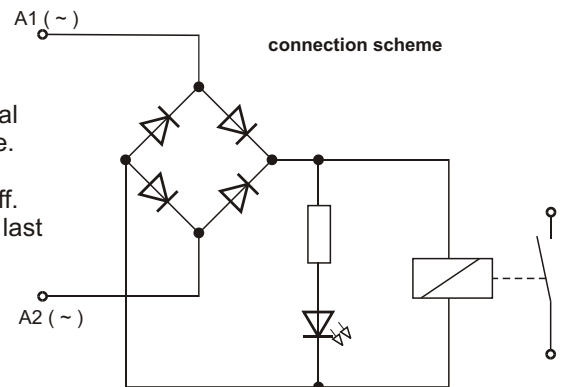

Please read the data sheets and the user manual for further information