

product specification

DC-DC converter DCC9024-1

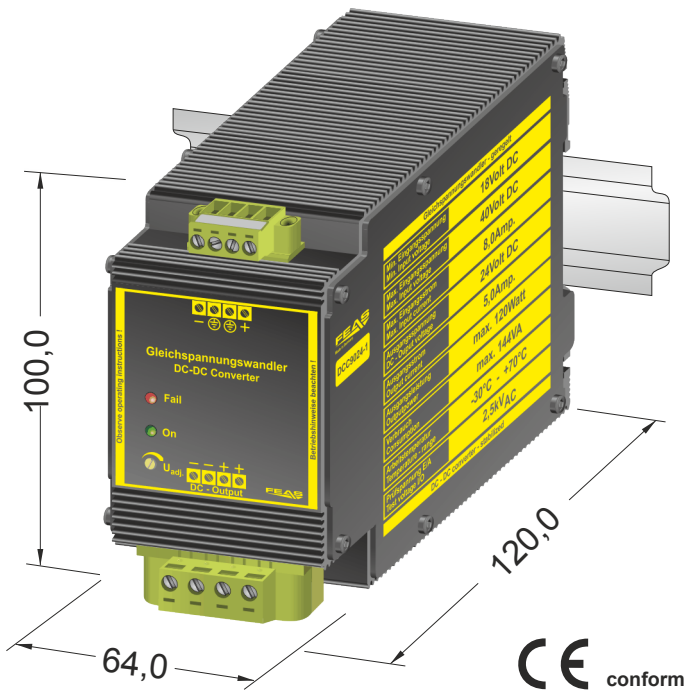

- Output 18.....40Volt DC
- Input 22,5.....30Volt DC (adjustable) / I_{Nom} 5A
- Regulated output voltage
- Output separated acc. to VDE0551
- Extra low safety voltage
PELV (EN 50178) SELV (EN 62368)
- Short circuit proof,
overload- and open circuit protected
- Parallel operation possible to increase output power
- Operating status shown by LED
- Simple mounting on rail acc. to DIN 46277
or wall mounting with screws
- Vibration proof, suitable for the tropics
epoxy resin casted
- Conforms to EMC and low voltage directive CE
- Safety acc. to VDE, EN, UL, CSA

Application

The robust DC-DC converters of the **DCC9024** series supply your sensitive loads with the required DC voltage. They convert the DC voltage supplied at the input into a DC voltage with a higher or lower voltage level. Thereby, the short-circuit-proof DC voltage at the output can be adjusted in the range from **22.5 to 30VDC**. This means that the DC-DC converters can also supply standby batteries in parallel operation or can be used for loads that require a high starting current. The powerful DC-DC converters from FEAS are suitable for supplying sensitive loads in harsh industrial environments. The DC-DC converters are integrated into a functional and stable aluminum housing and have good radio interference suppression and high functional reliability.

Funktional principle

The primary switched DC/DC converter DCC90 works according to the principle of the forward converter. In the forward converter, energy is transported in two steps. In the first step, energy is taken from the supplying power source and transferred to the output circuit. This transfer is controlled (switched) by a switching transistor. In the second step, the transistor opens and no energy is transferred to the secondary circuit. The energy flow in the secondary circuit is sustained by a storage choke. The switching transistor is turned on and off by a control voltage. The output voltage depends on the duty ratio of the switching transistor. It is constantly measured and fed back to the control circuit. In this way, a stabilized output voltage is generated.

Design

Completely embedded with resin in a aluminum housing for mounting on a rail or wall mounting with screws.

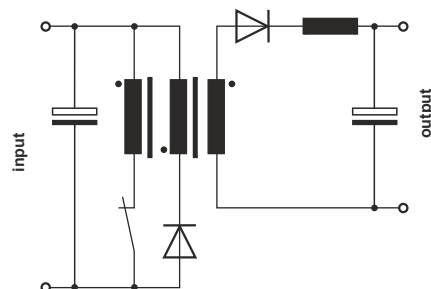
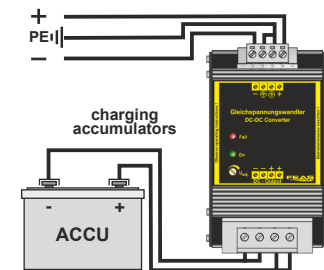
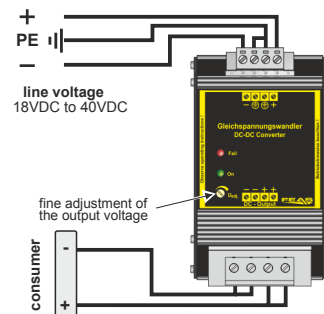

 Please read the data sheet and the user manual for further information.